



INKOS®

*Flotation*

## Rotational flotation machine Supraflot LC

Rotational arm DAF unit SUPRAFLOT LC is suitable for treatment of strongly polluted wastewater and for industrial process water with high concentration of floatable suspended solids.

SUPRAFLOT LC is a high tech-small volume equipment operating at zero hydraulic velocity in separation volume. This new principle is based on proprietary research and design. In contrary to other flotators, in SUPRAFLOT LC is wastewater introduced into the separation volume by rotating arm and clean water withdrawn by same arm.

This unique design enables operation at constant conditions even at variable flow and concentration of suspended solids. Raw wastewater as well as air saturated water are introduced along the tank radius. In the same way is withdrawn clean water. Speed of rotation is controlled in a way to tranquillise the water in the flotator. The trajectory of flocs with attached bubbles from the rotating arm to the surface is minimised. Because of this unique hydraulic phenomena, SUPRAFLOT LC is several times smaller than convectional volumetric flotators.

### Equipment advantages:

- high efficiency in separation, up to 99%
- minimal equipment dimensions, up to 20x smaller than other types
- high level of sediment thickening, up to 7%
- large size scale, 5 - 1 500 m<sup>3</sup>/h
- automatic operation starting and shutting down
- operator-free process
- very favourable ratio price/performance
- very high indexes of the performance /effective area, in comparison with conventional flotators

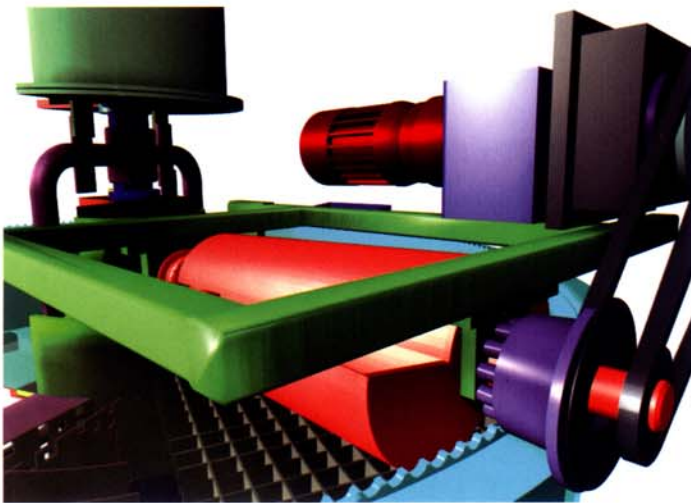
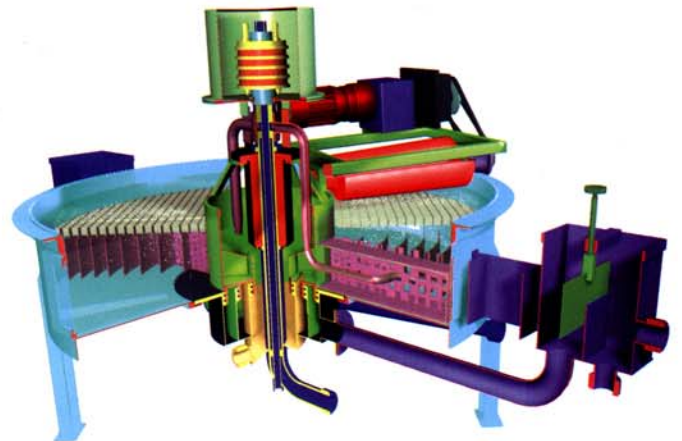

## Areas of using The Air Dissolved Flotation

**INDUSTRIAL WASTE WATER** – food, paper, textile, and chemical industry.

Meat industry and dairying produce a lot of waste water originating from the production itself and, in the case of meat industry, from the slaughter. The water is significantly polluted by a high level of fat. In such case, the flotation might be used efficiently. The waste water, after being roughly cleaned and coagulated, reaches the flotation device, where the separation is executed. The flotote is taken to further processing and the cleaned water fulfils the sewerage limits.



*Flotation station in a creamery*

**The Dissolved Air Flotation** is one of the most progressive methods of water cleaning and treatment, sufficiently proved and tested through lots of installations.

It is based on the separation of impurities from liquids with the help of micro sized bubbles of gas dispersed in the liquid. The bubbles are attached to particles of suspended solids, which are brought up to the surface. With the help of previously used particles coagulation, it is also possible to separate dissolved solids precipitated by chemicals.

During the Dissolved Air Flotation, a part of the cleaned liquid is saturated by the air in the independent device equipment. A higher efficiency of the flotation is achieved by mixing the saturated liquid with unpurified water.

The separation process of insoluble substances by the flotation might be also used for thickening sludge suspensions.

## INKOS supplies complex solutions for water cleaning with Dissolved Air Flotation

### Flotation tests

- during every flotation solution, we execute laboratory tests to optimise the efficiency and cost-effectiveness of the process
- before each new installation or based on customer's demands, we execute pilot-plant tests at the installation site with the use of the mobile flotation unit containing a minimum-sized standard flotation machine

### Equipment supply

- rotational flotation machine Supraflot LC
- SM air dissolving tube for the compressive water saturation by the air
- flocculation reactor
- chemical system
- control system with visualisation
- all the auxiliaries (tanks, pumps, switchboard)

### Service supply

- optimal technical set design
- realisation project
- assembly
- turn key project supply possibility
- warranty and after-warranty service



Mobile flotation unit

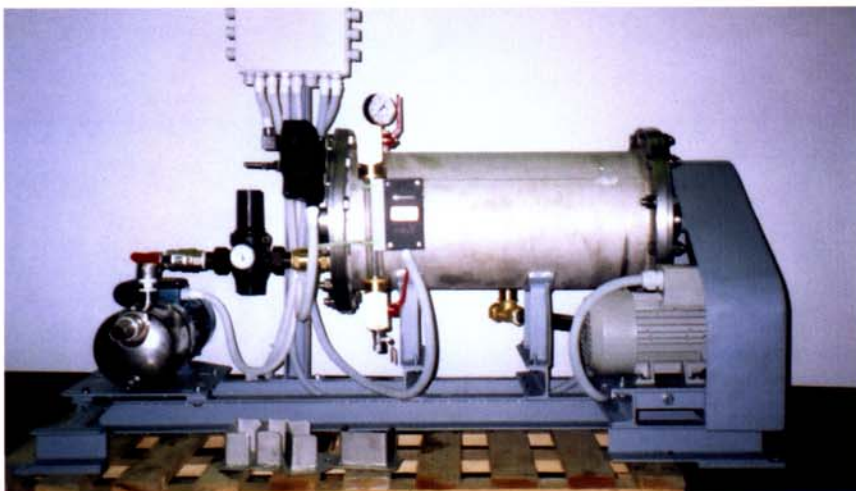

SM blender for the compressive water saturation by the air

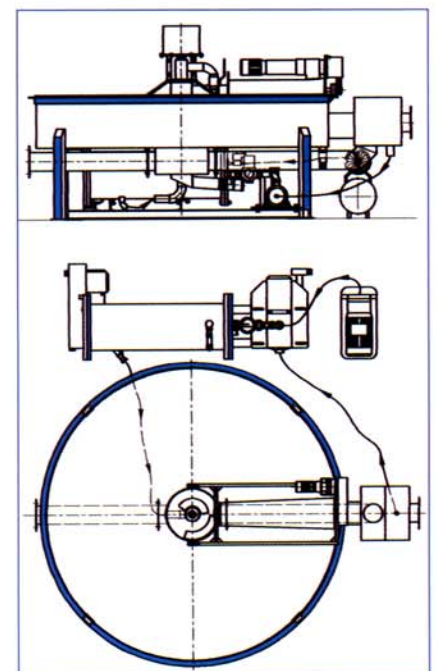

Flotation unit scheme

**TECHNOLOGICAL WATER** – metallurgy, petrochemistry, pulp, and paper.

In paper-mills, an important source of losing the under-size water of paper-making machines. The existing solution means draining the water into the sedimentation tank. The sedimentation efficiency is very low and a significant amount of cellulose leaves, with the waste water. The experience proved the high flotation efficiency when processing this water and an interesting savings. Another area of using the flotation is cleaning cooling water from various technological processes. The water circulating in the cooling circuit is getting polluted by various smears (oils, lubricants, dust, etc.). The level of pollution increases with the time, and after reaching a critical point, it is necessary to let the cooling circuit out and liquidate the polluted water, which is economically very demanding. Placing a flotation machine into the cooling circuit solves the question of the running disposal of smears and other impurities from the cooling water.

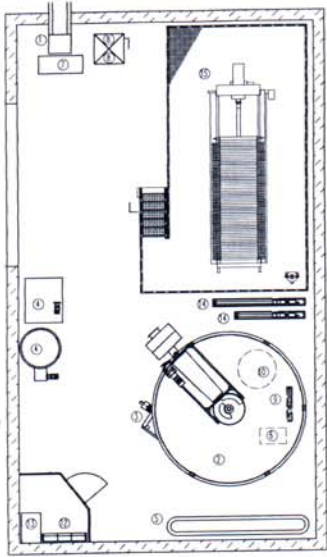

*Flotation station in aluminium works*

The sedimentation efficiency is very low and a significant amount of cellulose leaves, with the waste water. The experience proved the high flotation efficiency when processing this water and an interesting savings. Another area of using the flotation is cleaning cooling water from various technological processes. The water circulating in the cooling circuit is getting polluted by various smears (oils, lubricants, dust, etc.). The level of pollution increases with the time, and after reaching a critical point, it is necessary to let the cooling circuit out and liquidate the polluted water, which is economically very demanding. Placing a flotation machine into the cooling circuit solves the question of the running disposal of smears and other impurities from the cooling water.

**POTABLE WATER**

When treating potable water, the flotation is used before the sand filtration. Its use in the technology of WTP replaces the sedimentation, increases the filtration efficiency and decreases the space needs of a plant.

**MUNICIPAL WASTE WATER**

In the area of municipal sewage treatment plants the flotation may be used replacing the sedimentation if the arising sediments settle down with difficulty and naturally incline to the flotation. In contrary to the sedimentation, the flotation needs much less space.

**THICKENING OF SEDIMENTS**

The use of flotation during the thickening of sludge before drainage shows a high economy in space needs and fastens the whole process, as contrasted to classical ways.

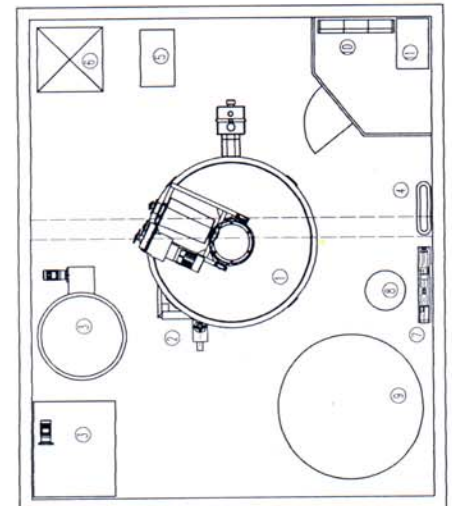

*Chemical dosage unit*



*Detail of the flotation surface*



INKOS, Vinohradská 76, 618 00 Brno, Czech Republic

